



Terry 
total mobility solutions

HARMONY HOMELIFTS

Restricted to the ground floor of a conventional house?

Regain the freedom of your home by being able to travel between floors smoothly, quietly and safely either seated in our Compact model or in our Harmony wheelchair lift.

The installation of a through floor lift is a far less complicated operation than you might think. Following the initial survey and the subsequent decision to proceed, our experienced team of fitters will carry out all necessary preparatory work and install the lift in less than two days with very little disturbance to your household.

Sometimes space is limited, therefore the Harmony range features an integral ramp and ingenious car design resulting in a wheelchair lift which is only fractionally larger on the outside than the inside.

For people who do not use a wheelchair, the Harmony Compact seated model requires just two thirds of the space of the standard Harmony.

Operation is simple. Having called the lift from the easily accessible wall control, sited to suit user, the car door can be opened by the same control. The low integral ramp allows easy wheelchair access and a push button inside the car closes the door. A push of the control button will signal the car to travel to the other floor, automatically lifting or replacing the aperture ceiling panel en route, where the reverse procedure is followed to exit the car.



Harmony allows you to move between floors smoothly and safely. Can be used with or without your wheelchair. Fold-up seat available.



Harmony Compact at lower level with fixed seat.



Lower room when lift upstairs



Upper room when lift downstairs



Entering the lift upstairs

Both lift-up aperture infill and carriage underpan are designed to provide a minimum half hour fire protection and both are fitted with smoke and intumescent fire seals. Pressure sensitive safety surfaces are incorporated in both which stop the lift if the lift is obstructed.

Interfloor aperture infill lifted automatically by the carriage

Safe edge around upper edge of carriage to stop lift if obstructed

The lift is fitted with electrical door interlocked to the carriage and light as standard

Powered door on wheelchair model



Harmony carriage controls

Toughened safety glass windows which do not scratch like plastic

A steel liner is fitted into the floor aperture to provide a sealing face for both aperture infill and underpan



Harmony wheelchair model optional grip handles

Pressure sensitive safety platform underpan doubles as ceiling closure and fire / smoke seal

No unsightly hydraulic ram, concealed in guide

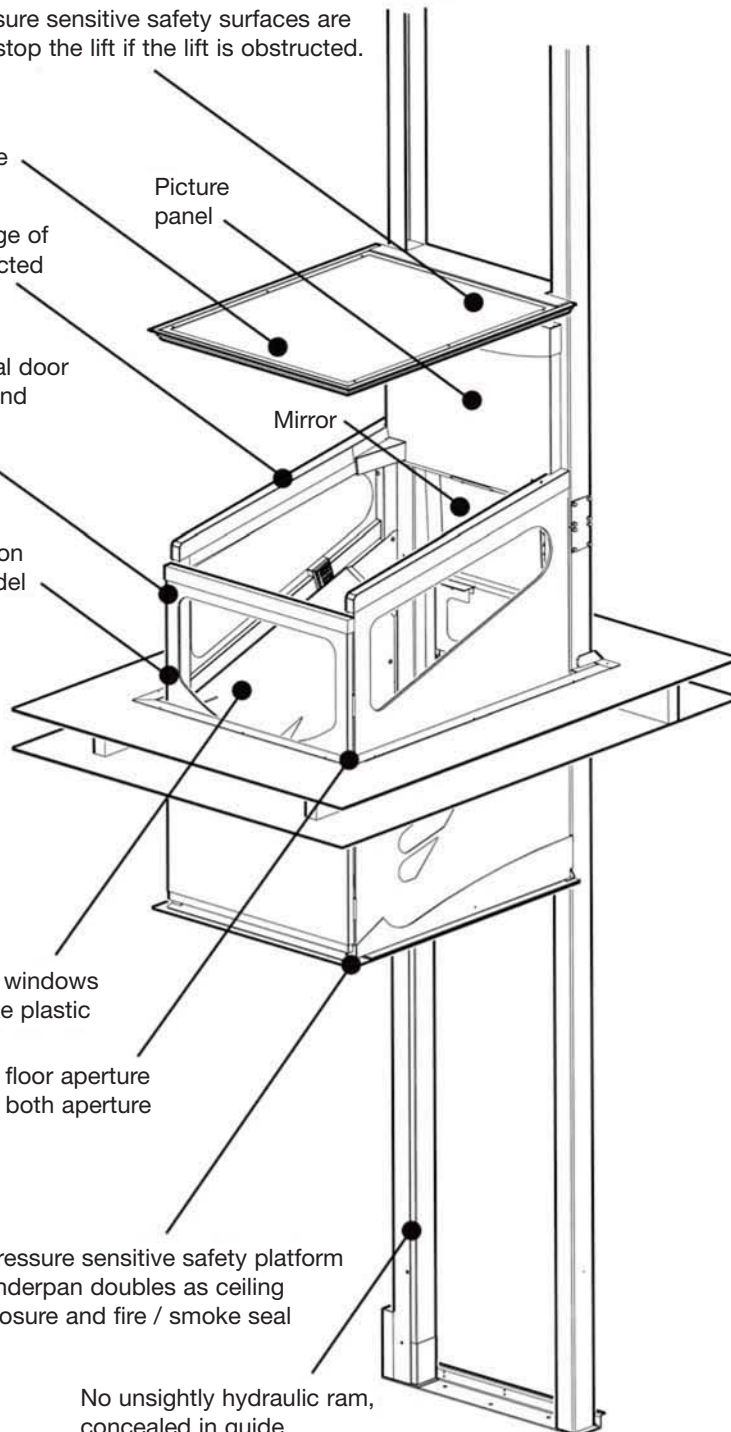

Moving downstairs



Lift approaching lower floor



Exiting the lift downstairs

State of the art hydraulic drive system provides the following benefits:

- Exceptionally smooth and quiet operation by virtue of remote power unit
- Inherent safety system to guard against free fall of car
- Flexibility of installation - minimal headroom required in first floor room and guides can be installed across windows or against non-load bearing walls

Standard features are as follows:

- Manufactured and tested to BS 5900. Warrington Fire Research Centre assessment WF 174734
- Usable floor space on the standard wheelchair model is the largest in the UK market
The longer wider model is the only through floor lift available on the UK market that will accommodate all category A & B wheelchairs
- Half hour fire integrity maintained in ceiling/floor irrespective of whether lift is parked upstairs or downstairs
- Radio wireless controls in car and at both floors which enable travel, stop and door open/close commands. No unsightly surface trunking
- Powered door on wheelchair version
- In event of power failure battery back up system allows operation of car in the down direction by normal controls with all safety systems in operation
- Low floor construction ensuring easier wheelchair access and egress
- The lift car side panels are fitted with lights which switch on when the lift is called

* Please note – The lift cabin styling shown in this brochure is available on all models except for the Harmony C model. Please contact us if you require further information.

Available options:

- Separate sliding seat in compact model
- Folding seat in wheelchair version (380mm W x 465mm D. Height from floor 510mm)
- A telephone can be fitted in the lift car
- A range of trim colours
- Special car sizes in wheelchair model 200mm longer 150mm wider or both
- Left or right door handing

Harmony Wheelchair Carriage Details

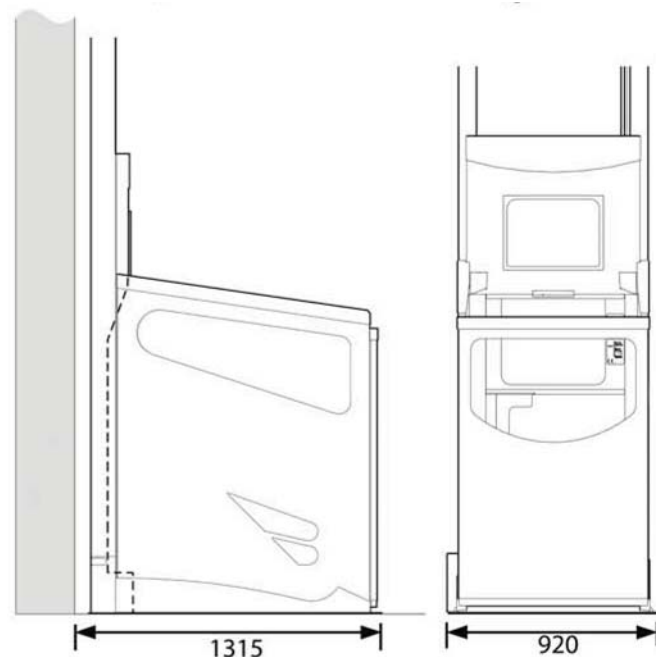

All dimensions in mm

Travel: From 2060mm to 3650mm

Capacity: Wheelchair 250kg (39 Stone)
 Compact 150kg (23 Stone)

| Lift Model | Internal Width | Internal Length | External Width | External Length |
|--------------------------------|----------------|-----------------|----------------|-----------------|
| Harmony C * (Compact) | 560 | 680 | 710 | 965 |
| Harmony S (Std. wheelchair) | 755 | 1175 | 920 | 1315 |
| Harmony W (Wider) | 890 | 1175 | 1055 | 1315 |
| Harmony L (Longer) | 755 | 1375 | 920 | 1515 |
| Harmony LW # (Longer Wider) | 890 | 1375 | 1055 | 1515 |

All dimensions in mm

Terry 
 total mobility solutions

Terry Group Ltd.
 Longridge Trading Estate,
 Knutsford, Cheshire, WA16 8PR

Tel: 0845 365 5366
 Fax: 0845 365 5367
 email: sales@terrylifts.co.uk
www.terrylifts.co.uk



Made in England



British Healthcare Trades Association

